

Artikel-Nr. / Part-No. / N°article : **550S137.1SW**
 Produkt / Product / Produit : **Crash Pad Anbausatz /
 Crash Pad Mounting Kit /
 Kit de montage pour Crash Pad**
 Fahrzeughersteller / Vehicle Manufacturer / Application : **Suzuki**
 Modell (Typ) / Model (Type) / Modèle (type) : **SV 650 ABS '16 →
 Gladius / ABS '09 - '15**

Stückliste:

1 Buchse, l=45mm	→ „1“	1 Schraube M10x1,25x85mm	→ „7“
1 Buchse, l=50mm	→ „2“	1 Schraube M10x1,25x90mm	→ „8“
1 Grundplatte rechts „S137R“	→ „3“	1 Schraube M12x1,25x345mm	→ „9“
1 Grundplatte links „S137L“	→ „4“	1 Mutter M12x1,25	→ „10“
1 Halter 45mm	→ „5“	2 U-Scheibe 1mm / 2,5mm	→ „11“
1 Halter 55mm	→ „6“	2 Crash Pads (separat zu bestellen!)	

Prüfen Sie die Lieferung auf Vollständigkeit

Parts list:

1 spacer, l=45mm	→ „1“	1 allen bolt M10x1.25x85mm	→ „7“
1 spacer, l=50mm	→ „2“	1 allen bolt M10x1.25x90mm	→ „8“
1 bracket right “S137R”	→ „3“	1 bolt M12x1,25x345mm	→ „9“
1 bracket left “S137L”	→ „4“	1 nut M12x1,25	→ „10“
1 support 45mm	→ „5“	2 washer 1mm / 2,5mm	→ „11“
1 support 55mm	→ „6“	2 Crash Pads (order separately!)	

Check for completeness

Composition:

1 entretoise, l=45mm	→ „1“	1 vis M10x1.25x85mm	→ „7“
1 entretoise, l=50mm	→ „2“	1 vis M10x1.25x90mm	→ „8“
1 plaque d'adaptation droite, réf.: S137R	→ „3“	1 vis M12x1,25x345mm	→ „9“
1 plaque d'adaptation gauche, réf.: S137L	→ „4“	1 écrou M12x1,25	→ „10“
1 support 45mm	→ „5“	2 Rondelle 1mm / 2,5mm	→ „11“
1 support 55mm	→ „6“	2 Crash Pads (commande à part!)	

Vérifiez si la livraison est complète!

Wichtig: Wenn Sie kein ausgebildeter Mechaniker sind, wenden Sie sich bitte an eine Fachwerkstatt. Es gelten folgende Anzugsmomente, falls nicht in der Zeichnung anders angegeben: M6 = 10Nm; M8 = 20Nm; M10x1,25 = 35Nm; M12x1,25 = 70Nm. Für alle Verschraubungen mit Rahmen oder Motor gelten die Anzugsdrehmomente des Fahrzeugherstellers. Die Montage muss seitenweise erfolgen, keinesfalls die Motorhalterung auf beiden Seiten gleichzeitig lösen.

Important: If you are not a trained motorcycle mechanic stop now. Ask a local motorcycle shop to do the work for you.

If not otherwise mentioned, the following tightening torques are recommended: M6 = 10Nm/7.4lbf ft, M8 = 20Nm/14.8lbf ft, M10x1.25 = 35Nm/25.8lbf ft ; M12x1,25 = 70Nm/51.6lbf ft. Refer to the vehicle manufacturer's instructions for all connections to frame or engine. Fitting needs to be done side by side, never loosen the engine support on both sides at the same time.

Important: Adressez-vous à un atelier spécialisé si vous n'êtes pas mécanicien.

Sauf indication contraire, utilisez les couples de serrage suivants:

M6 = 10Nm; M8 = 20Nm; M10x1.25 = 35Nm ; M12x1,25 = 70Nm.

Pour tous les vissages au niveau du châssis ou du moteur, utilisez les couples de serrages indiqués par le fabricant. Le montage des Crash-Pad s'effectue d'abord d'un côté puis de l'autre! Ne jamais desserrer simultanément des deux vis tenant le moteur!

Montage rechts / Fitting right side / Montage côté droit:

Crash pad Kit provisorisch ausrichten und handfest montieren, danach fest montieren.

Align the Crash pad Kit temporarily and install it hand-tight, then install it firmly

Kit de Crash pad align provisoire et serré à la main monté, puis montage fixe

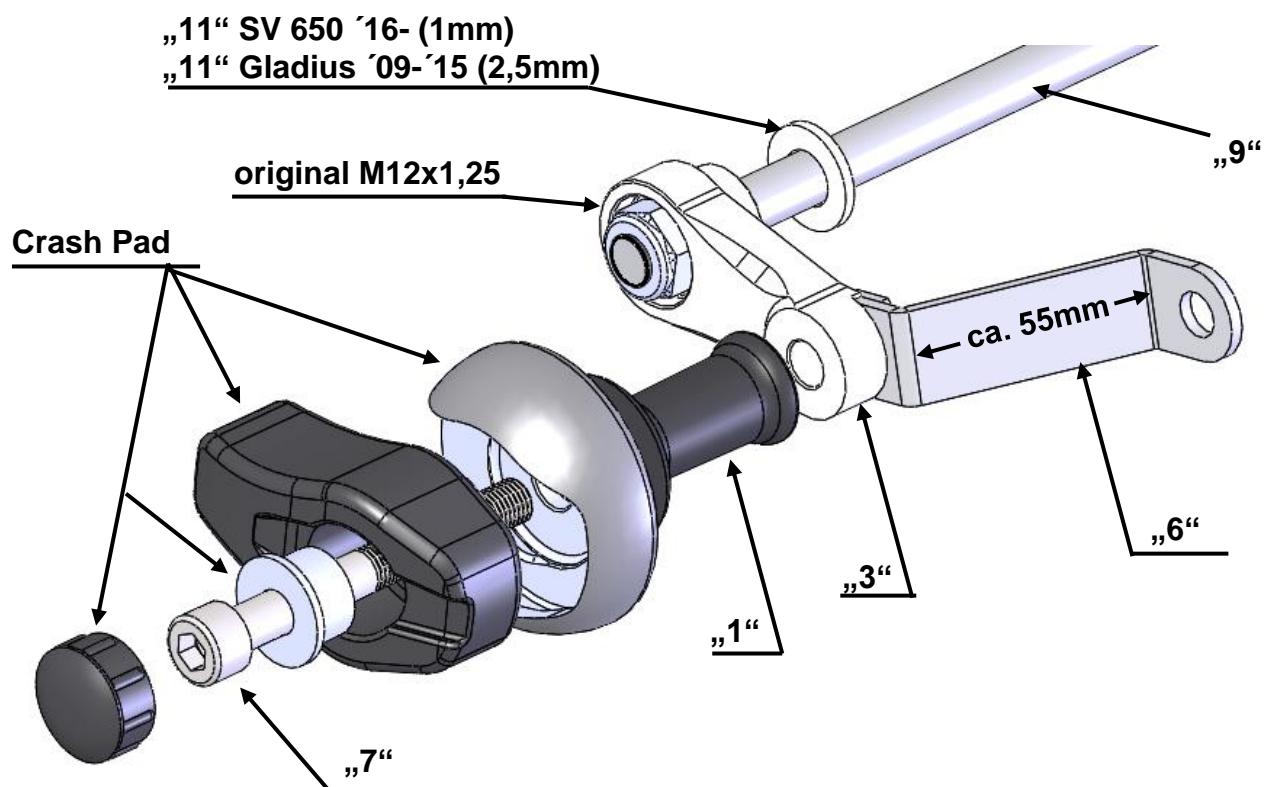
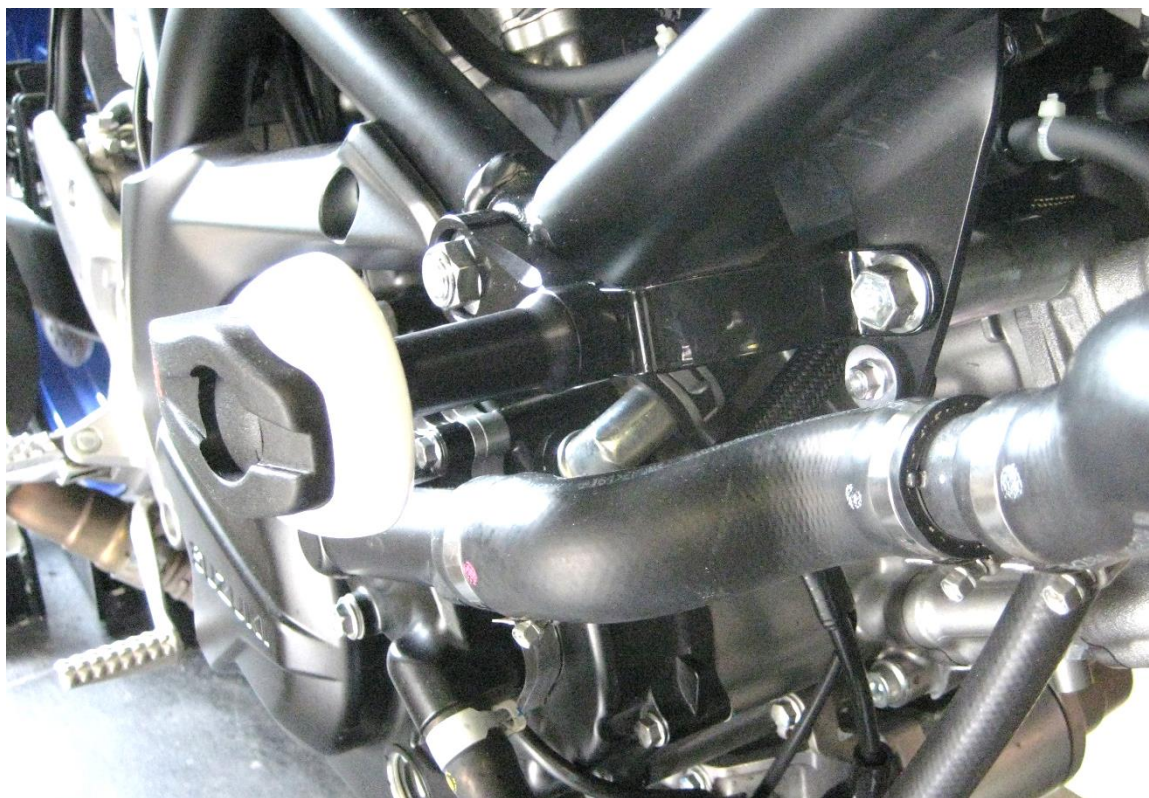

Montage links / Fitting left side / Montage côté gauche:

Crash pad Kit provisorisch ausrichten und handfest montieren, danach fest montieren.

Align the Crash pad Kit temporarily and install it hand-tight, then install it firmly

Kit de Crash pad align provisoire et serré à la main monté, puis montage fixe

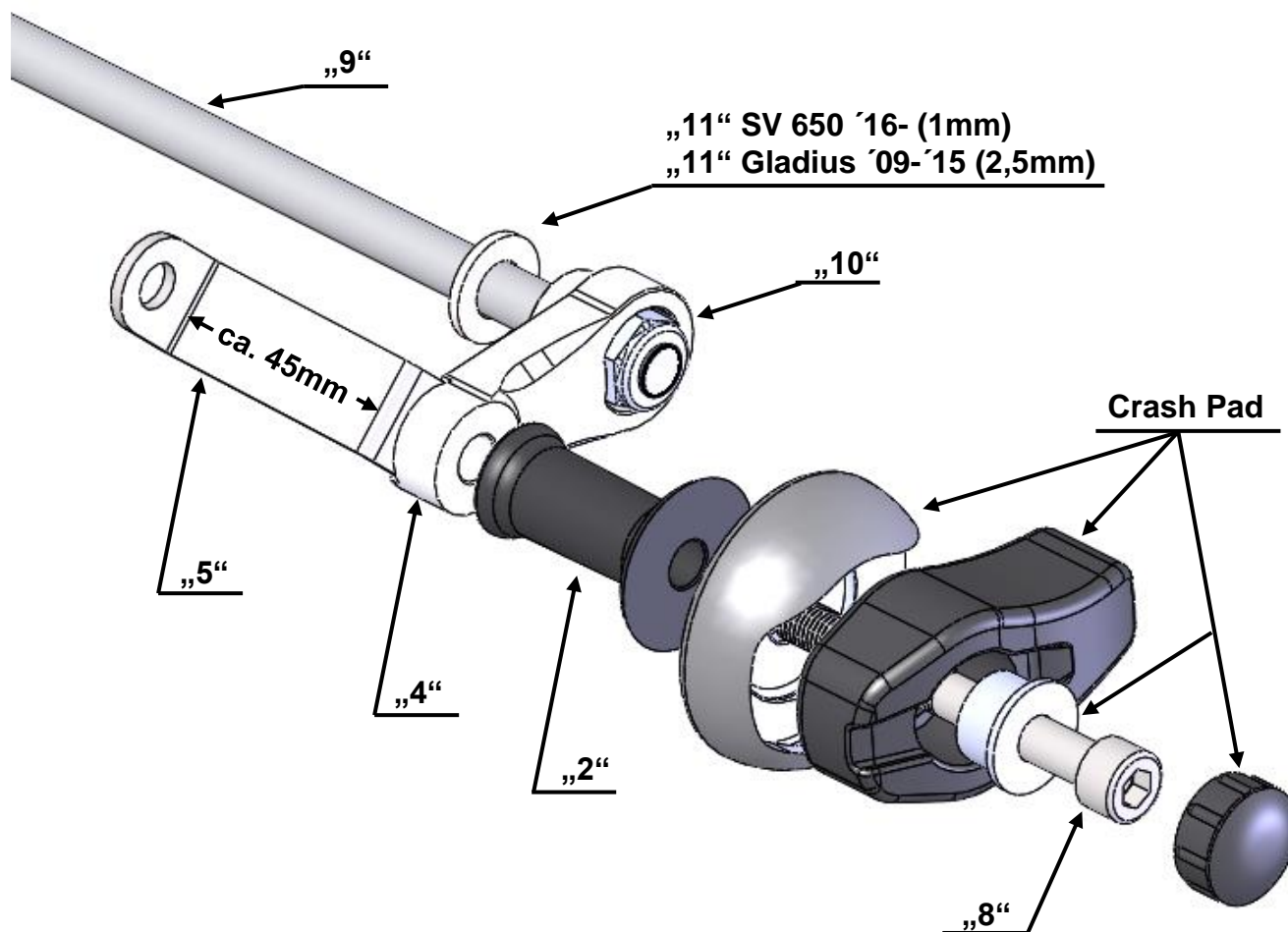
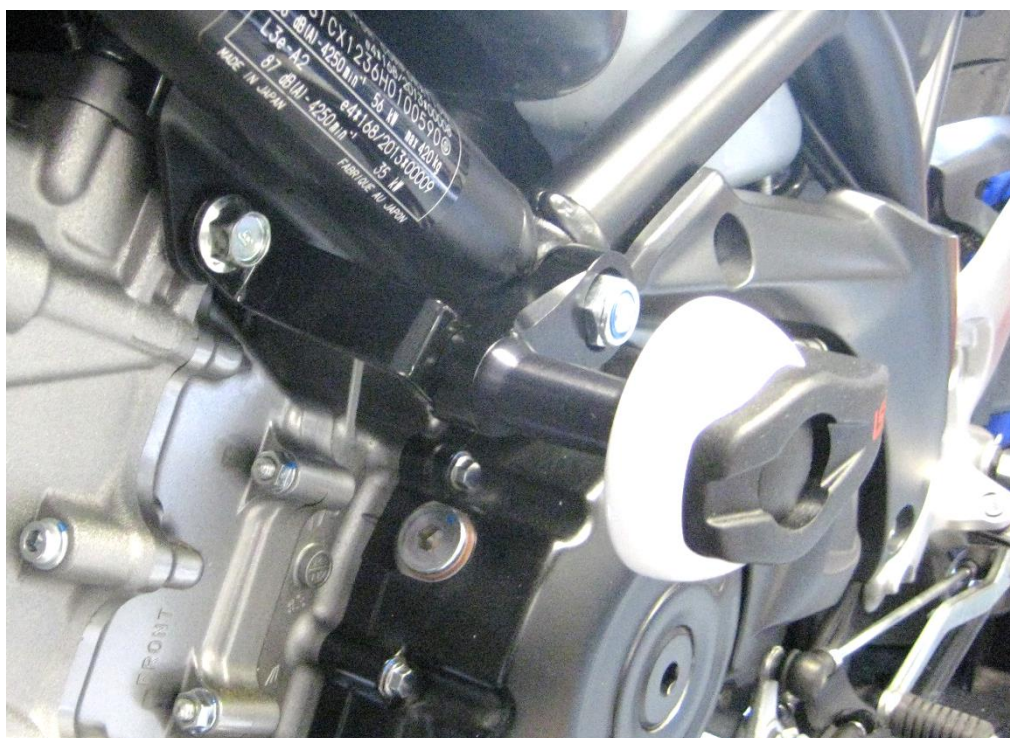

Gladius '09 - '15

1.

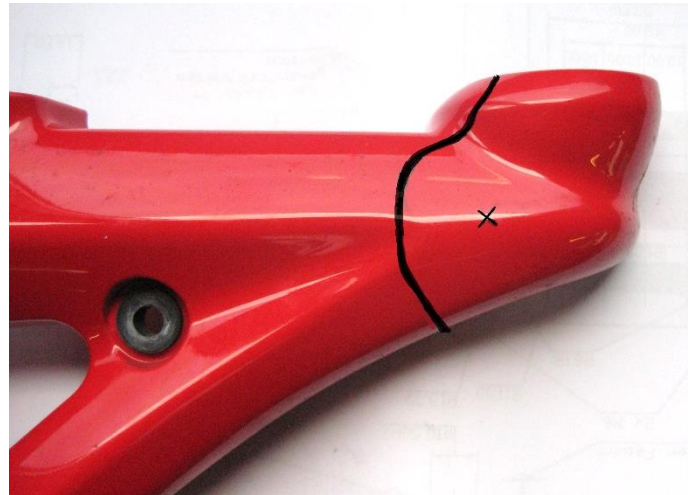
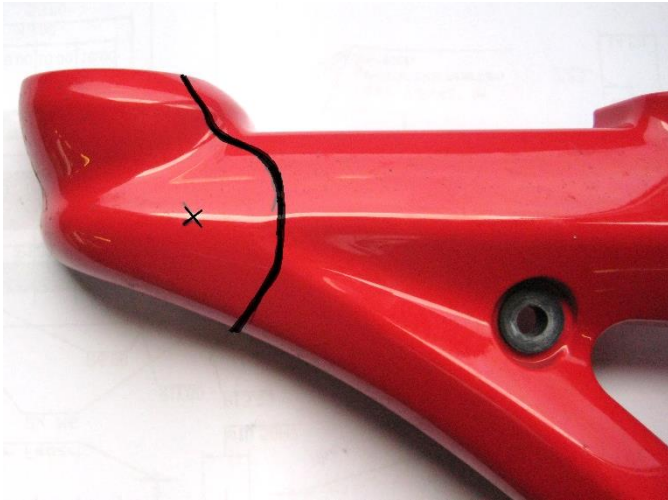

2.



3.

